

## **SYSTEM DEPLOYMENT STRUCTURES - A NEW GENERAL FORM OF ROBOTIC CONSTRUCTION AGENT**

Jonathan B. O'Brien,

University of New South Wales, School of Civil Eng., Sydney 2052, Australia.

### **Abstract**

This paper examines the problem of the development of industrially useful general purpose robotic construction agents and discusses a number of key intellectual constructs used to create them. A new abstract form, umbrella notion based around the idea of systems deployment structures is presented. The implications of thinking with this new notion are discussed and a number of practical applications presented.

### **1. INTRODUCTION**

A robotic construction agent (RCA) can be defined as a self-contained, functional system capable of fully or quasi-autonomously executing at least one complete field construction task. General form RCA's and task specific form RCA's can be envisaged and full or part task applications developed. Whilst RCA machines, which are single micro-task oriented, part-task specific or single function, can be locally very useful (especially in high repetition environments) the full potential of RCA's in an industry with limited task or product repetition will only come from the development of general purpose RCA's. Such machines have to be able to execute a sufficient variety of different field operations to execute a complete normal work package. Alternately they must be able to handle a wide form of parametrically defined field task.

Undoubtedly, the design of industrially acceptable forms of general purpose RCA's comprise a major technical and commercial challenge. As of now however, the likely best starting point for the creation of general purpose RCA's would seem to be to utilise programmable manipulators and autonomous vehicle technology. The AV's can act as materials supply and haul units or as bases for a mobile, manipulator arm equipped, vehicle. Programmable manipulators can be developed in many forms and sizes and can have various mountings. Generally however, these forms of machine were conceived of originally as pick and place or load manoeuvring devices for fundamentally free air conditions rather than as full multi-function devices and force application machines. Current forms of manufacturing PM's have evolved as quite small, normally one limbed machines, that can handle light loads and light power tools through use of an end gripper. Where the work is suited to the machine type and the scale can be amplified, however, very sophisticated and industrially useful one-armed manipulator type RCA's can be developed [1]. For general form, on-site, construction work however, current form one-armed manipulator based systems are quite unable, by reason of versatility, technical

or scale reasons to complete most of the types of jobs encountered. What is needed are more flexible, total job, machinery systems which can multi-task as well as large scale work access and handling systems which can be cheaply developed. With both form of system there is a need to be able to work over large sites and be capable of cooperating and interfacing with a number of diverse form autonomous agents as well as being able to deal with human based construction systems and mixed agent systems.

In order to physically realise these new forms of machinery system in a commercially viable manner within the existing construction industry framework, it is this authors belief that new ways of thinking about the robotic construction agent problem are urgently needed.

Given this motivation, this paper aims to analyse some traditional ideas relative to RCA's and to develop some wider form notions that can form the basis for the creation of economically effective RCA's. These notions aim to deal with homogeneous and heterogeneous systems of automatic and non-automatic construction agents, composite machine systems and to handle the interface that exists between human-based construction systems and robotics-based construction systems.

## **2. MIND SETS AND INTELLECTUAL CONSTRUCTS**

Intellectual constructs are mental devices used to structure and organise perception and to organise thought processes[2]. The type and quality of mental constructs employed in thinking also have major implications for research quality and ideas fertility as does the supplemental issue of an individual's or a culture's whole 'mind-set'.

In cognitive theory terms, the label 'manipulator' denotes a particular organisational and categorisational construct which is well established in industrial robotics. The label covers well the typical range of pick and place robotic devices and tool handlers used in modern production engineering. As an intellectual construct however, the term 'manipulator' carries with it a number of major connotations in the form of a master/slave, subject/object form, manipulator/manipuland ideas and so on. The construct does not cope well with isometric push or pull situations, active or complex manipulands or situations where a number of locally intelligent disparate devices may be utilised in a task execution context. Nor does it cope well where a number of manipulator modules are stacked one upon then other, operated as branched architecture or where the manipulator may be operating in inverted mode with its base free. To overcome the limitations of the manipulator construct and in order to develop a new high level of abstraction concept on which to base a comprehensive theory of RCA's, the author has developed a new wider form intellectual construct - based on the idea of a 'system deployment structure'.

## **3. DEFINITION OF A SYSTEM DEPLOYMENT STRUCTURE**

The general form of an SDS is as set out in figure 1. The primary constituent is an orthodox civil or mechanical engineering structure which has been developed around, or can utilise, a number of external reaction points for whole body stability. Secondary components or elements comprise one or more systems or equipment packages which are mechanically coupled to the main or basal system.

For the basal system to be considered to be able to 'deploy' the attached systems through free air into a prescribed position, to manoeuvre them along desired trajectories or to otherwise move them against external resistance the basal structure must be internally powered and capable of continuously varying its overt geometry and structural length against load. The shorthand notation 'VGS' will be used here to denote this general class of powered structure. A third component in the SDS system is a controller. Whilst in fully automated systems this may be a computer system, in tele-operated systems it may be a human or a human with computer assist. In systems with multiple actuators which are needed to be operated synchronously and concurrently, computer assistance is generally necessary. A fourth component is a variable action element (VAE). This element allows for the selective coupling of an attached system to the VGS.

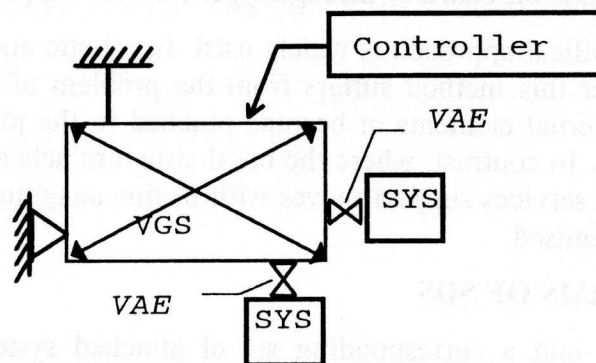

Figure 1 - The abstract form of a System Deployment Structure

The form of the basal structure can be any of a number of load-bearing mechanisms - such as serially chained rigid element links mechanism or more complex powered spatial linkages. Typically it will be a multiple degree of freedom powered device operated as an 'active' structure. Additionally, the structure can take a Stewart platform type of form [15], a variable element triangulated space frame trussed form [14] or be a variable wire rope based structure. In addition to these mechanism types, there are a number of construction machines that can be deemed to be fully effective VGS structures. Thus dam-site cableways, draglines, hydraulic excavators, builders hoists, boom lifts, air-leg drill stands and mobile cranes all have the VGS feature. Also, through the addition of such elements as thrust bearings, friction drives or wheels, racks and pinions and so on the basal structure can be made locally or globally mobile or turned into a fully mobile vehicle such as a truck, bulldozer or gantry.

In in-animate form, applied systems may comprise passive elements, implements, functional devices, non-powered tools, powered tools or simple or complex instrumentation packages. These may be further developed into mixed collections or sets of devices or into multiple work-head systems. The applied system may be quite complex e.g. sensor packages and remotely operated TV systems operating in local flying mode through furred masts [9]. Alternately, animate systems, in the form of human construction agents, can be embraced by the concept of a flexibly attached system. Single or multiple humans can operate on the surface of basal structure as mobile friction drive active agents. Mixed human and in-animate systems can be developed.

The structural connection between the basal structure and the attached system can be in the form of a variable geometry structure or a mobile or flexible connection. This may

permit an attached system to traverse over the surface of the basal structure or to gain general structural support from it through such devices as tethers.

#### **4. ACTIVE SYSTEMS AND THE SERVICES SUPPLY PROBLEM**

In the synthesis of economically useful SDS's, services supply issues pose significant engineering problems. Once one moves away from passive to active attached systems there arises a need to provide these systems firstly with appropriate services and secondly with connections to the master controller. In logical terms these needs can be met by use of either (a) Independent supply lines in the forms of umbilical systems connected to external sources or (b) through the use of internally developed services systems. Under this second arrangement, the attached systems may draw their necessary services from the basal system through appropriate, on-board or through type, services supply systems.

Of these two approaches, the umbilical approach is widely used. In robotic and complex site applications contexts however this method suffers from the problem of long lines which tend to get snagged on external elements or become pinched in the joints of the basal VGS during its manoeuvres. In contrast, where the basal structure acts as a parent body and the attached system and services support moves with it, line snagging and line damage problems are greatly minimised.

#### **5. MULTI-FUNCTIONAL FORMS OF SDS**

It is possible to develop a SDS and a corresponding set of attached systems, for a particular situation on a bespoke or custom tailored basis. Clearly however any system so developed would have to bear all tooling and R&D costs. If on the other hand one seeks to minimise cost or develop a multi-purpose system one may seek to use the same basal structure with a variety of attached systems, a different approach to design is needed. One needs to build into the SDS 'attached system exchangeability features' or systems that allow for the detachment of one form of attached systems and attachment of others. To allow these features to be developed one needs to create bundled or individual, multi-form, services as well as removable connections interfaces. These interfaces can take the form of multiple independent, flexible or fixed location, services outlets or of systems connected to a major internal reticulation system. Alternately surface based multi-form services manifolds can be designed

In alternative designs of SDS, the main basal VGS could have the main services reticulation systems developed as either an internal or as an external "arterial system". The first design has benefits in the form of protection from damage and of neatness, the second allows access for maintenance.

#### **6. ATTACHED SYSTEMS EXCHANGE CAPABILITIES**

Up until now, SDS's have been discussed where the attached system were presumed fixed or un-changed through a full machine operation cycle. If, however, one provides an extra feature in the form of a remotely operable mechanical connections and services connection interface or programmable VAE (ref fig 1), it is possible for the VGS to change or exchange attached systems under program control. This allows selection of a range of special purpose tools and devices from an 'implements and systems library'. This approach has been pioneered by the Schilling Co. in their range of multi-tasking telerobotic manipulators [3]. In fully automatic mobile systems, the tools library may be

carried on the body of the machine in a series of holsters or holding bays, delivered to the machine by an external agent or else obtained autonomously from an external store or repository. The provision of a programmable VAE facility allows the VGS to drop off and pick up active machinery packages or elements. Thus a large VGS building a transmission tower could drop-off a local action insertion and bolt-tightening machine.

Simple one-armed manipulators have limited intrinsic action capabilities. Where complex multi-tasking work is to be achieved, dual limbed systems are better. In terms of SDS theory this implies branched architecture systems with multiple disparate attached systems that can be independently programmed as to action and desired behaviour.

### **7. ABSTRACT FORM SDS'S AS FULL TASK CONSTRUCTION AGENTS**

If a, generalised form, SDS with programmable VAE facilities is given access to a set of remotely exchangeable instrumentation heads, mechanical action heads, tool heads or process based end-effectors (such as sand-blasting or welding units) it becomes capable of doing randomly sequenced mixed multi-task work. Further, if the whole system can be suitably externally programmed in task-space or set-up internally to program itself, the system is then fully capable of doing complete field tasks without external assist. Operated in this mode, the overall SDS system constitutes a fully valid, full-task 'robotic construction agent' as per our original definition. If an abstract form SDS can meet our criterion for RCA it is then becomes apparent that the RCA notion can be realised in a large number of diverse mechanical forms since it is the inner form not the mechanical exterior or form of practical embodiment that is relevant .

### **8. BENEFITS OF THIS NEW CONCEPTUALISATION**

The benefits of this new form of robotic agent conceptualisation are firstly that it facilitates the development of new forms of system based around unorthodox structures (such as crossed Trussarm type space frames structures). Secondly it allows generation of structures suited to large span and large load applications. Thirdly it allows for much easier discussion of auto-tool changing systems, sub-systems deployment notions and especially of 'configuration-changeable work-systems' and hybrid systems. Fourthly, it greatly facilitates thinking about dynamic parent/dynamic child robotic systems - especially where the child system is potentially free roving or sometimes piggy-backed.

### **9. PARTICULARISATION OF THESE IDEAS TO CONSTRUCTION**

For application of these ideas to on-site construction work, basal systems with a large operational compass, lift capacity and flexibility as to working range are obviously highly desirable. For work around very large sites fully independent rugged terrain mobility is also required. Since a number of normal construction machines already have these features these can be used as the VGS. Suitable systems include: self propelled scissors and boom lifts; rack and pinion hoist and cross platform access systems; stabilised wire rope based machine access systems; pile driving equipment equipped with power operated leaders; mobile cranes, telescopic handlers and man-elevator lifts; self propelled gantry cranes and straddle carriers; rough terrain fork-lift trucks and FEL's. Suitably equipped, these systems can deploy a target working package or active construction agent across a large surface or through the volume of a large construction site. These basal VGS forms of construction machines can be readily adapted to remote or computer controlled operation and can be provided with suitable on-board services

and down-stream device controllability features so as to allow composite action of the whole. These trends are already evident in that already a number of researchers have proposed the use of basically standard construction machines as basal elements in large scale construction robotics systems.[4,5,6,13]

To the basal systems proposed here, a large variety of utility packages and construction tools [7] as well as fully fledged robots can be attached.[8, 10]

The use of the SDS concept allows one to treat cascaded, hierarchical, hybrid and multi-work front systems. Thus a combination of an access mast with cross-girder system and say a tradition travel-track based industrial robot is seen as a simply realisable possibility. Likewise, an X-Y traversing platform based, multi-headed, total task locally intelligent and facile building facade inspection and repair system could be placed atop a mobile crane based VGS with multiple DOF supplementary limb ( figure 2). In this instance the tool library would be located on the X-Y platform itself.

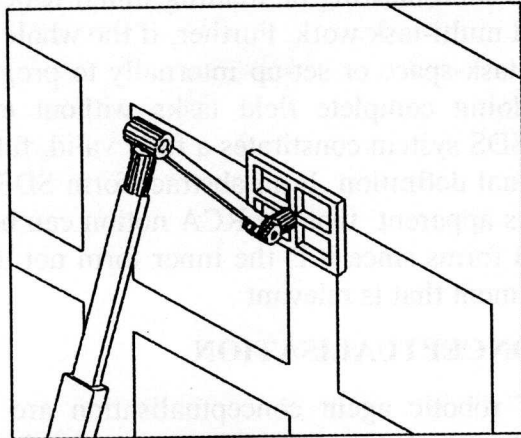

Figure 2 - Schematic of a fully automatic total facade inspection and repair system deployed by a multiple degree of freedom boom.

The SDS notion also allows for the mixing of human based and robotic based systems. Thus one may have a case of a human acting as the active attached system element to a very large robotically controlled boom structure - as for instance abrasive blasting of an oil supertanker. The boom may have been set up to auto-track the doubly curved surface profile of the supertanker whilst the human provides local fine control.

On large scale sites, the idea of a large system discretionarily deploying small systems can be developed to great advantage. Thus for example, small welding machines for in-situ welding operations may be deployed by a large robotised gantry crane around a large ribbed steel fabricate - such as the interior of a ship's hull. In this case the parent and the child system are fundamentally different in character and each has a form of strength, intelligence and autonomous control suited to its particular application.

## 10. TOTAL WORKSTATION CONCEPTS

In many situations it very useful to be able to develop a single machine that does many different functions.. By application of the SDS concept with tool interchange, it is possible to develop systems that are in construction terms, multi-functional. Thus the author has completed concept design studies for single machines that can produce ordinary concrete pad foundations without human assist. Sensor equipped machines,

operating on a real-time self programming mode and using exchangeable specialised tool heads, can excavate a hole, place and fix reinforcement and place, vibrate, screed, trowel and cure the concrete. The concept machines cooperates with a computer controlled boom equipped concrete pump for concrete delivery and vibrates the concrete concurrently with its delivery with normal immersion type poker vibrators.

### **11. SOME PROTOTYPICAL RCA SYSTEMS**

To give some practical feel to the concepts that have been developed to date, a number of system that are already in existence and which may used as mental prototypes for complex forms RCA systems can be cited. These include: a maintenance robot [9], construction machines equipped with robotic action heads. [7], cascade form toxic waste cleanup robots [10] and force-reflection multi-limbed teleoperators[3].

### **12. THE VERY LARGE RCA SYNTHESIS PROBLEM**

Using existing industry proven technology, it is now quite practical to access the full facade of a major story building by use of a face based climbing mast and beam system. [11,5]. By adding to this a traversing robot system with multi-function tool exchange kit, an economically viable full remote operations system for the face of a building can be developed. Similarly, rough terrain scissors lifts can be used to access the underside or the facades of structure Alternately, active tooling systems can be deployed across large spaces by he use of wire rope based structural systems [12].

### **13. APPLICATION OF THE TOTAL WORKSTATION CONCEPT**

Using the total workstation concept, systems for the fully automated repair of road surfaces can be developed. These systems would combine surface inspection, crack and hole cleanout and pothole filling functionalities. Similarly, total station installation of underground pipes using an hydraulic excavator as VGS can be envisaged. The system could dig, level, place, align, joint and backfill the pipe to laser level without worker assist. In a similar manner, complete building facade and physical assets inspection and maintenance systems can be developed as can light steel framed building erection systems, formwork and falsework erection system and full remote operation building demolitions systems.

### **14. INDUSTRIALISATION IMPLICATIONS**

By viewing RCA systems as hybrid machines and by allowing individual machinery manufacturers to perceive robotic devices as extensions of their existing range of product rather than as new and exotic specialist machines, one can now reformulate the industrial construction agent development problem as an open-systems architecture problem rather than as a closed system architecture one. Such a reformulation should allow independent firm development of sub-system and modular forms of RCA. This view, by permitting multi-firm involvement, should also generate forces for industry cooperation and interface standardisation and may permit industry wide solutions to the all-critical device-economics problem [7] to be developed.

### **15. CONCLUSIONS**

This paper has presented a new, umbrella type, abstract form intellectual construct for discussing and developing robotic and RCA systems. The new unifying construct is

believed to be considerably fertile in the process of generating new ideas and useful in allowing for the development and invention of new forms of RCA's. It is concluded that active structure based robotic systems, married exchangeable to an array of close-coupled powered end attachments and end-type active systems, comprise a set of new, powerful and versatile forms of robotic field construction agent with great economic potential.

## REFERENCES

- [1] Vaha, P. and Heikkila, T " Autonomous paper roll manipulator" p15-22 Industrial Horizons, VTT Technical Research Centre of Finland, Espoo, Finland, April 1993.
- [2] Bannister, D and Francella, F. " Inquiring Man - theory of personal constructs" Penguin 1971.
- [3] Schilling, T. (1990) " Increasing the efficiency of telemanipulators through the robotic exchange of end tooling" Intl. Jnl. of Robotics and Automation vol 5, No. 1 1990 pp 16-19.
- [4] Tondu B. et al " A Facade Working Robot - The Eureka/Geo Project 4th ISARC, Haifa, 1987 p94.
- [5] Terauchi S. et al 'Development of an Exterior Wall Painting Robot Capable of Painting Walls with Indentations and Protrusions' 10th ISARC 1993, pp 285-292.
- [6] Ibanez-Guzman ' Simulation of a Panel Positioning Robot' 9th ISARC, Tokyo, 92 pp. 451-457.
- [7] O'Brien J.B. " Robotic action heads - New forms of attachment to existing construction machines" 11th ISARC, Brighton, U.K May 1994..
- [8] Chamberlain, D. A. (1992) "A rebar detection robot" 9th ISARC, Tokyo 1992, pp 251-260.
- [9] Horne, R.A. 'Teleoperator evolution at CERN' in Teleoperation and Control ed C.A. Mason 1988.
- [10] Bath W.R. "Cascaded manipulators for long reach dexterity and high capacity " American Nuclear. Soc. Winter Meeting November 1991.
- [11] Modular Mast Climber technical literature - Malmquist Ltd.
- [12] Freund A. 'Automated Surface Finishing of Large Diameter Storage Tanks' 8th ISARC, Stuttgart, 1991, p189.
- [13] Nagaoaka, A. et al 'An Automatic Concrete Transit System ' 7th ISARC, Bristol, 1990 pp 39-46.
- [14] "The Trussarm manipulator" University of Toronto Aerospace Division Annual Report 1992.
- [15] Viscomi W. 'Automated Construction in the Atlas Integrated Building System' 10th ISARC '93.